



“Complete Solutions of  
**Hospital** Equipment”







## Modular OT

### Antimicrobial Cladding Type

Antimicrobial cladding solutions for hygiene-critical areas in operating theatres, medical facilities and laboratories.

#### The Specification

Tiny particles of silver ions deliver an authentic sterile performance. The active ingredients contain no toxins and prevent the growth of bacteria, mould and viruses-including MRSA and food contaminants. Thermo-formed corners for a seamless finish perfect for optimum antimicrobial performance.

#### Method of Fixing

Sheets are fully bonded to suitable substrate with two-part polyurethane adhesive. All joints should be hot welded using colour-matched Weldrod with one part divider offering transition between wall and floor.







## Modular OT

### Stainless Steel Finish

The inner surface walls will be fixed to the bricks wall with essential supports. There will be minimum possible cavity/gap in between the solid and steel walls. The total distance between the inside and outside surfaces of the operating room will be variable to suit the architect's layout. But will be sufficient for the flush mounting of equipments. The individual wall panels will be spot welded together at equal intervals to render equal support to the panels. Spot welding will be properly grinded to make the surface leveled.



#### Features:

- 1.6 mm thick S.S panels, backed by 12mm thick gypsum
- S.S- 202 or S.S- 304 stainless steel panels
- Laminated panels under high pressure as per EN standard
- for best and durable results
- PUF sandwich panel
- All the sharp edges and corners will be in radius to avoid bacteria contamination.





## Modular OT

### Antibacterial Painted

The room wall will have two independent surfaces with a minimum opening in between. The external walls of the room will be constructed with solid bricks with cement plastering. Operation Theater Wall, Sloping, Risers and Ceiling The wall panels will be constructed using both side PPGI / EGP sheet and with core consisting of rigid polyurethane foam, which has been injected under high pressure, with a minimum density of 40 kg/m<sup>3</sup>. The gaps between panels shall be suitably filled with metal filler/epoxy and sanded flush.



### Features:

All the sharp edges and corners will be in radius to avoid bacteria contamination. The internal surfaces of the room walls will be sprayed with water based liquid plastic, wall glaze or equivalent, approved by the architect to a minimum dry film thickness of 300 microns. The plastic coating will overlap the floor covering, ceiling system and doorframes by 25 microns to provide a continuous sealed surface. The plastic coating will be nonreflective and the color will be submitted to the architect for approval





## Ceiling System Design

- Metal ceiling is made of individually detachable panels with Customise dimensions.
- The substructure is made of galvanized steel
- Panels are fixed in clip-in system.

## Surfaces

- Galvanized or stainless steel, powder coated, optionally with antibacterial paint.
- Standard colour is RAL 9010. Other color available optionally
- Matt, washable, light resistance surface
- Dust-free, abrasion-proof, corrosion resistant, non-hygroscopic.



## Laminar Air Flow

Laminar plan air ceiling system with unidirectional airflow with "S" class HEPA filter with an efficiency 99.97% down to 0.3 micron.



## Antistatic Flooring

Seamless Epoxy Flooring. 2mm thick Anti static, conductive dissipative flooring tile laid on a semi conductive adhesive base resistant to mechanical stress and dynamic load and washable.

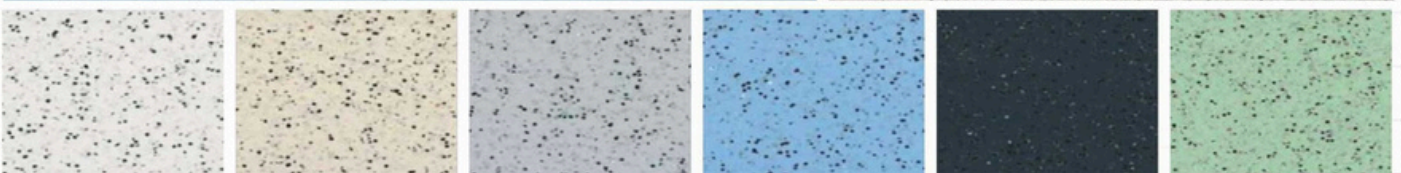

0350 Light Grey

0353 Beige

0352 Grey

0354 Blue

0351 Black

0355 Green



# Hermetically *Sealed Sliding Door*

Automatic / Manual Hermetically Sliding Doors with glass vision window along with other accessories.



To maintain satirically and the correct air pressure in the room, all doors into and out should be of the sliding, hermetically sealing type. Design should meet HTM 2020/2021 standards. The doorframe should be made of high quality anodize aluminum and the door panel should be made of compact laminate that can withstand high abrasion. To ensure efficient sealing seal on all four edges in the closed position & should be surface installed type.

HPL Single Leaf

S.S 304 Single Leaf

HPL Dual Leaf

S.S Dual Leaf



## Single & Dual Arm *OT* Pendants

OT Pendants are made of aluminium extruded profiles duly powder coated. Creative OT Pendants are having provision for Gas Outlet Points, Electrical Sockets, Nurse calling, RJ45 Data Points, RJ11 Telephone points, Audio jack, Video Jack, IV Pole, Infusion pump pole, Suction bottle clamp, Equipment tray upto 5 as per requirement. Our Pendants are having 330 degree rotation and are available in fixed, swivel, single arm & double arm.



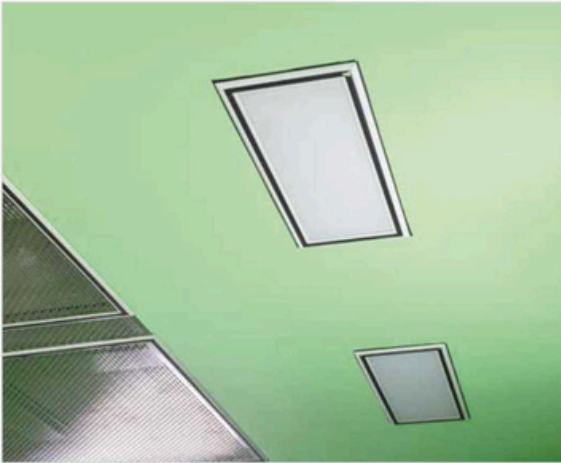

## Peripheral Lights

Recess mounted non- hygroscopic Peripheral Light for clean Room Application LED options for peripheral light also available.



## Pressure Relief Damper

Pressure Relief Damper. Made up of 304 graded stainless steel blades with all accessories. Blades for maintaining the positive pressure inside the operation theatre.



## Pass Box

2 door Pass box made up of Stainless steel grade 304. One door will be opened at one time, indicator on both sides. The box will be designed in such a way that only one door will opened at one time. The UV light will glow when both the Door are in closed position.



## Surgeon Control Panel

Membrane type / Touch type Operation Theatre Control Panel mounted flushed in the theatre wall with complete distribution board with all accessories.

- Day Time Clock
- Elapsed Time Clock
- General Lightening System
- Medical Gas Alarm
- Hand Free Telephone set
- Temperature & Humidity indicator with controller
- HEPA Filter Status module
- Room Pressure Indicator
- Music System
- Differential Pressure
- AHU Control
- OT Light ON/OFF





## Scrub Sink Station

2/3 Bay Scrub station Manual or Automatic, made up of Stainless steel grade 304 with all accessories inclusive of photo sensors with timer, thermostatic mixing valve & bypass system, with foot switch.



## X-Ray Board

Single / Two / Three plate X-Ray viewing screen LED with dimmer & complete accessories.

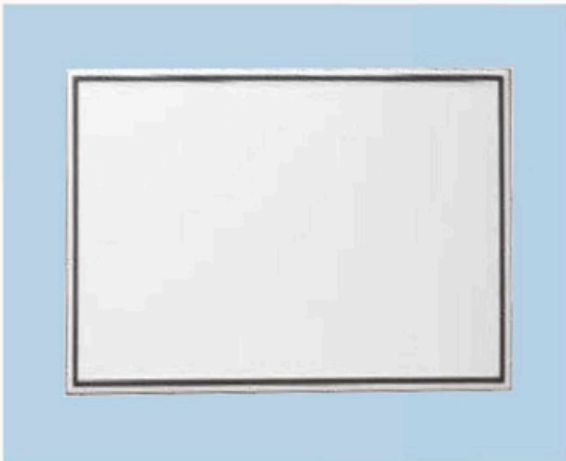

## Writing Board

One operating list board should be provided in each operating theatre. It should be made of ceramic having Magnetic and should be flushed to the wall of operating room.



## Air Handling Unit

Air handling units of GSS sheet metal cabinet pre & fine filter type double skin one pre coated & one side plain G.I. SHEET 25-43mm thick (section 30mm) modular construction. Air handling units Curved Centrifugal Fan, motor drive, DX & IGT Type Cooling Coil, filter section with 10 micron Filter.



# Operation Theatre

## LED Surgical Lights

Perfect Shadow Free Illuminance Effect

Thanks to large amount of led lights and multiple Emitting positions of led light sources any obstructions With surgeon's shoulder or hands will not affect the Surgical wound area with any cast shadows



## Maximum Economy & Highest Reliability

- Its technological advances make it a good long term investment due to low maintenance and operating running cost. With various light head configurations, it maximizes the comfort of the surgeon and forbids the tissue dehydration even during long time operations.
- The minimal life expectancy of each LED is 50,000 hours
- Sophisticated LED thermal management keeps the temperature-rise of the space above surgeon's head and surgical region extremely low.



### Sliding Top **Five Function Electrical OT Table** with Dual Remote



### **OT Table Hydraulic C-Arm Compatible**

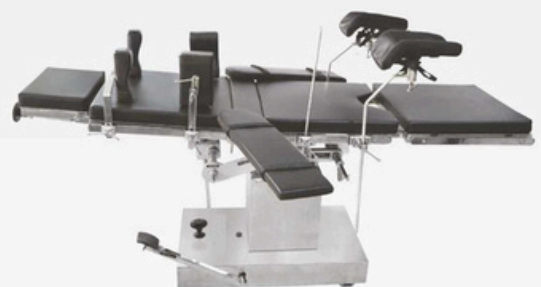

Length of Table	1900 mm
Width of Table Top	520 mm
Minimum Height (without Mattress)	Min. 750 mm
Maximum Height (without Mattress)	Max. 1000mm
Trendelenburg	25°
Reverse Trendelenburg	25°
Lateral Tilt	±20°
Back Section	±20°
Head Section	±60°
Leg Section	0°-90°
Top Sliding	5" Reverses & 5" Forward

- Eccentric Pillars
- Stainless Fitting
- Detachable, head, leg & Pelvic section
- Five Sectional Radio - Translucent Top.
- Base & Cover made of attractive, easy to clean Stainless Steel
- Sophisticated mechanics provide smooth, step less articulation of the table Top for precise patient positioning.
- Stand by Battery Back-up with recharging circuit (Optional)



# Modular ICU



We provide complete customisation of I.C.U. solutions and ensure optimal utilisation of space and resources along with premium performance and maximum clinical functionality. Each one of our product is meticulously designed keeping in mind the client's aesthetic requirements and the patient's ergonomic needs! At Shreyal Medico lab industries (SMLI) we ensure that our I.C.U. solutions are developed to create a positive "healing environment" and facilitating speedy patient recovery - be it mental or physical.

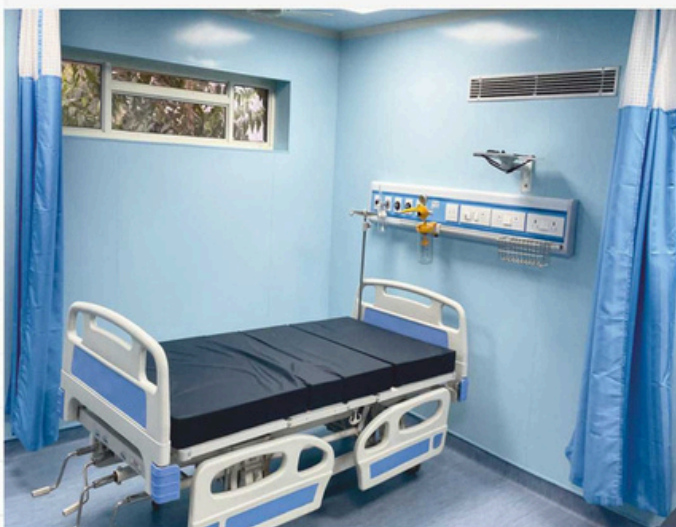



# Medical Gas Pipeline Solution

All our solutions are complying with different type of standards

As professionals in projects designing and installation of medical gas pipeline system, we provide you with a wide range of products, equipment and services in addition to the supply of medical gases. **Shreya Medical System ( SMLI )**, provides top notch products and services ensuring the safety of our customers and patients and the reliability of supply.

- Main Gas Stations
- Medical Compressed Air Stations
- Medical Vacuum Stations
- Anaesthetic Gas Scavenging Systems
- Cryogenic Tanks
- Medical Copper Pipes
- Pressure Regulator
- Valves
- Alarms
- Zone Valve Box with or without Alarm
- Medical gas Outlets

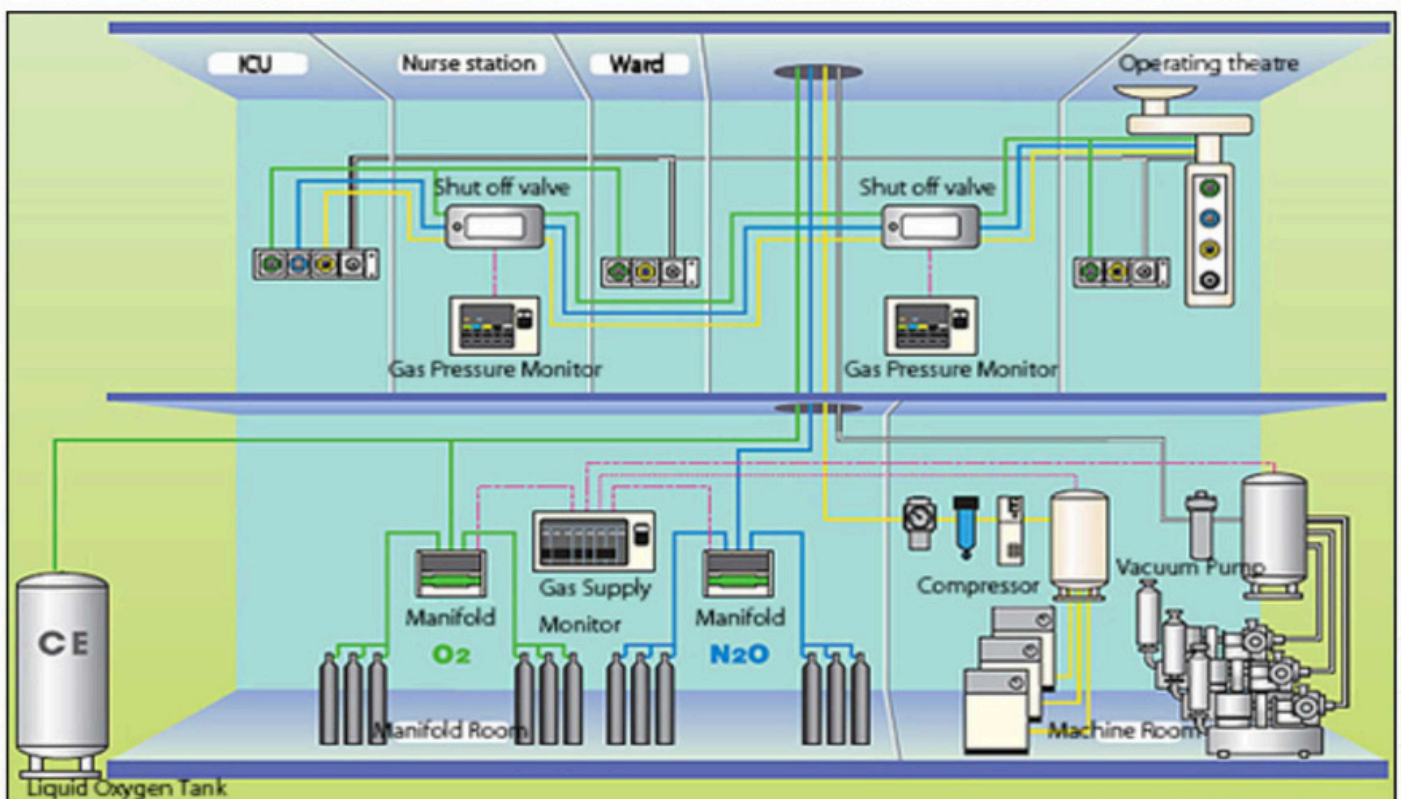





**Gas Manifold**



**Medical Air Plant**





## Vacuum Plant



Gas Alarm Panel



Valve Box



Fully Automatic Oxygen Control Panel



Semi-Automatic Oxygen Control Panel



# Medical Gas Accessories



B.P.C. Flow Meter



Mox Regulator



FA Valve with Flow Meter



IOX 14 Regulator



Parkodex Gas Outlet



BS Gas Outlet



Amico Gas Outlet

# Suction Units & Theatre Suction Unit



600 ml Jar with Regulator



1000/2000 ml Jar With Regulator



Suction Trolley



# Bed Head Panel

Sleek design made of Aluminum Powder coated material with provisions for Gas Terminal Units and sockets for power and monitor.

- Very easy to assemble and configure.
- Easy modification to match customer requirements.
- Sliding Bar for IV Pole, Suction Unit and Basket.
- Available in different colors as per requirement.





# Hospital Furniture



ICU BED MOTORISED



ICU BED MECHANICAL



MECHANICAL FOWLER BED



MOTORISED FOWLER BED (ABS PANEL)



SEMI FOWLER BED (ABS PANEL)



SEMI FOWLER BED (WOODEN PANEL)



PLAIN WARD BED (WOODEN PANEL)



PLAIN WARD BED (GENERAL PANEL)





ATTENDANT BED



FOOD TROLLEY



BED SIDE LOCKER S.S. TOP



EMERGENCY CRASH CARTS



STRETCHER TROLLEY



EXAMINATION COUCH



INSTRUMENT TROLLEY



PATIENT STOOL (REVOLVING) & VISITOR STOOL



# Contact

---



---

## Shreyal Medico Lab Industries

**Manufacturing Unit :** 48 ,B Building, Plot no. C  
-39/A , Gami Industrial Park , TTC Industrial Area  
Pawane , MIDC , Navi Mumbai -400710

**Call :** +91-9967282110 +91-8698971256

**Site :** [shreyalmedicolabindustries.com](http://shreyalmedicolabindustries.com)

Dealer / Distributor

